

# DARK LINK

## Owners Manual



*DOEPFER MUSIK ELEKTRONIK GMBH*



# DOEPFER

# DARK LINK

## User Manual



### Inhalt:

Safety Instructions.....	4
<b>1. Introduction</b>	
<b>1.1. Preface</b> .....	5
<b>1.2. Preparations</b> .....	6
1.2.1. Setup.....	6
1.2.2. Connections.....	6
<b>2. Overview</b> .....	8
<b>3. Functions</b>	
<b>3.1. MIDI Connections</b> .....	9
<b>3.2. MIDI Channel Selection</b> .....	9
<b>3.3. The MIDI-to-CV/Gate Interface</b> ....	10
<b>3.4. Learn Mode / MIDI Functions</b> .....	11
<b>3.5. The Glide Control</b> .....	14
<b>3.6. Initialisation</b> .....	14
<b>3.7. Firmware Update</b> .....	15
<b>3.8. Changing Gate-Signal and CV2</b> ... 16	
<b>4. Nuts'n Bolts of MIDI-CV/Gate Conversion</b> .....	17
<b>5. Addendum</b> .....	19

## **Safety Instructions**

*Please follow the instructions for use of the instrument carefully because this will guarantee proper operation of the instrument. Due to the fact that these instructions touch on Product Liability, it is absolutely imperative that they be read carefully. Any claim for defect will be rejected if one or more of the items has not been observed.*

*Disregard of the instructions can void the two years covered by warranty.*

*The instrument may only be operated at the voltage stated on the power input on the rear panel. Before opening the case, disconnect both power plug and power adaptor.*

*All eventual modifications are to be performed by a qualified person only in accordance with valid safety instructions. With the introduction of a third person, the warranty will be void. In case of a destroyed warranty seal, any warranty claim will be rejected.*

*The instrument must never be operated outdoors but solely in dry rooms. Never use the instrument in a humid or wet environment, nor near flammable goods.*

*No liquids or conducting substances must get into the instrument. Should this be the case, the instrument is to be disconnected from mains power immediately and examined, cleaned and possibly repaired by a qualified technician.*

*Never expose the instrument to temperatures above +50° C or below -10° C. Before operation, the instrument should have a temperature of at least 10°C. Do not expose the instrument to direct sunlight. Do not install the instrument near heat sources like heaters, open fire places, central heating etc. Keep the top of the instrument clear in order to allow proper ventilation, otherwise the instrument could eventually overheat.*

*Never place heavy objects on the instrument.*

*Transport the instrument carefully, never let it drop or fall over. Make sure that during transport and in use the instrument is supported properly and cannot drop, slip or fall over because people might get injured.*

*Never use the instrument in the immediate proximity of electronic devices (e.g. monitors, power supplies, computers) as these interferences could cause malfunctions within Dark Link and corrupt memory data.*

*The instrument is to be shipped in the original packaging only. Any instrument shipped to us for return, exchange, warranty repair, update or examination has to be in its original packaging! All other deliveries will be rejected. Therefore, make sure you keep the original packaging and technical documentation.*

*The instrument may only be used for the purpose described in this operating manual. Due to safety reasons, the instrument must never be used for other purposes.*

*When using the instrument in Germany, the appropriate VDE standards are to be followed. The following standards are of special importance: DIN VDE 0100 (Teil 300/11.85, Teil 410/11.83, Teil 481/10.87), DIN VDE 0532 (Teil 1/03.82), DIN VDE 0550 (Teil 1/12.69), DIN VDE 0551 (05.72), DIN VDE 0551e (06.75), DIN VDE 0700 (Teil 1/02.81, Teil 207/10.82), DIN VDE 0711 (Teil 500/10.89), DIN VDE 0860 (05.89), DIN VDE 0869 (01.85). VDE papers can be obtained from the VDE-Verlag GmbH, Berlin.*

## 1. Introduction

### 1.1. Preface

#### *Doepfer thanks you!*

First of all we would like to thank you for having purchased Doepfer Dark Link! We really appreciate your choice and promise you an extraordinary support throughout, including useful information, easy service, and innovative product development.

May your Dark Link be an important and useful tool for ages to come.

#### *What's this?*

Dark Link is an easy to use but pretty powerful USB/MIDI-to-CV/Gate-Interface. Monophonic Synthesizers that are not equipped with a built in MIDI Interface can be easily controlled via MIDI resp. MIDI via USB. Your synthesizer simply needs inputs for a pitch control voltage and a gate signal. Dark Link provides not only a pitch control voltage but also three additional control voltages that are derived from pitch bender, velocity and MIDI-controller data (e.g. modwheel) of your MIDI/USB keyboard. So it is most easy to hook up a vintage synthesizer in your MIDI setup. Dark Link is housed in a compact and solid metal enclosure. Power supply is an included 12-15 volt "wall wart".

#### *R.t.f.m.!*

We knew it: User manuals are your first and only choice in literature. Hey, that's great – we're talking the same language here!

If you are doubting the entertaining qualities of this manual – how dare you! –, please bear in mind that its thorough study will eventually turn out to be quite useful as it will highly increase the inspirational value of your new MIDI-to-CV/Gate interface. So please do yourself - and us - a big favor: Read (and, if possible, understand) this frigging manual! Thanks for your time, and bless you for your efforts!

In the first section you will find all info needed to successfully hook up Dark Link to your setup. After that, you will find a brief overview of its functions. Experts may use this as a quickstart guide. You should not skip the complete description of the entire "Functions" section in the next chapter, though – Dark Link hides some interesting features under its hood. If sequencer technology – especially the secrets of MIDI-to-CV/Gate conversion – are totally new to you, please refer to "Nuts and Bolts of MIDI-to-CV/Gate conversion" later on in this manual.

Enough babble - here we go...

## 1.2. Getting started

When lifting Dark Link out of its box for the first time, please make sure that everything is in its right place. You will find the following component parts in the box:

- Dark Link USB/MIDI-to-CV/Gate-Interface
- wall-wart (12V AC / 200mA)
- USB cable (A-B type)
- this owners' manual

*You will also need:*

- A suitable monophonic sound generation device with CV/gate connectors.
- A suitable MIDI/USB keyboard, -controller (e.g. a Doepfer master keyboard).
- At least two patch cables with 1/8" minijacks (to connect to Dark Link) and jacks, fitting to your CV/gate controlled synthesizer.
- (If nec.) a switch trigger cable to control some vintage Moog and Korg synthesizers (available at Doepfer or your local dealer).

To run Dark Link via its MIDI-DIN socket, you will also need:

- A MIDI cable to connect a MIDI master keyboard / controller to Dark Link.

### 1.2.1. Setup:

Please use a suitable support. Used pizza cartons or beer crates should not be your first choice. Don't say we didn't warn you.

### 1.2.2. Connections:

You do not necessarily need all its built-in sockets to get Dark Link going. For a simple setup, you will need just the ones pictured below. Make use of the additional terminals and you will tremendously expand Dark Link's potential. These connectors will be described later on in this manual.

- Power supply:

Connect the included power adaptor ("wall wart") to the **12V AC socket** on the rear panel of Dark Link.

**Important: Use this power adaptor only or an equivalent one with exactly the same specs!**

Powering Dark Link via USB is not possible since the internal analog circuitry of Dark Link runs at +/-12V.

- MIDI:

Connect Dark Link's USB socket with your suitably equipped keyboard or computer. Any configuration or driver installation work is not required on your computer. You will find more information about USB operation in chapter 3 "Functions" on page 9.

Connect Dark Link's MIDI-in socket with the MIDI-out socket of your MIDI keyboard to run Dark Link in a conventional MIDI setup without USB.

The default setting of Dark Link's MIDI channel is Channel 1. How to change this setting is described on page 9 in chapter 3. "Functions".

**Do NOT use MIDI-in socket and USB port simultaneously! Misfunctions may occur.**

- CV/Gate:  
Connect Dark Link's Gate socket to the gate input of your synthesizer.  
Connect Dark Link's CV-1 socket to the pitch controlvoltage input of your synthesizer.

At least these two connections are obligatory to run a voltage controlled synthesizer. The additional three control voltage provided by Dark Link (broken lines) make your voltage controlled synth "listen" to pitchbender, velocity and modwheel (resp. a MIDI controller of your choice). Please note that not all voltage controlled sythesizers are equipped with such inputs to handle these additional voltages.

The following pictures shows the most important connections to and from Dark Link:

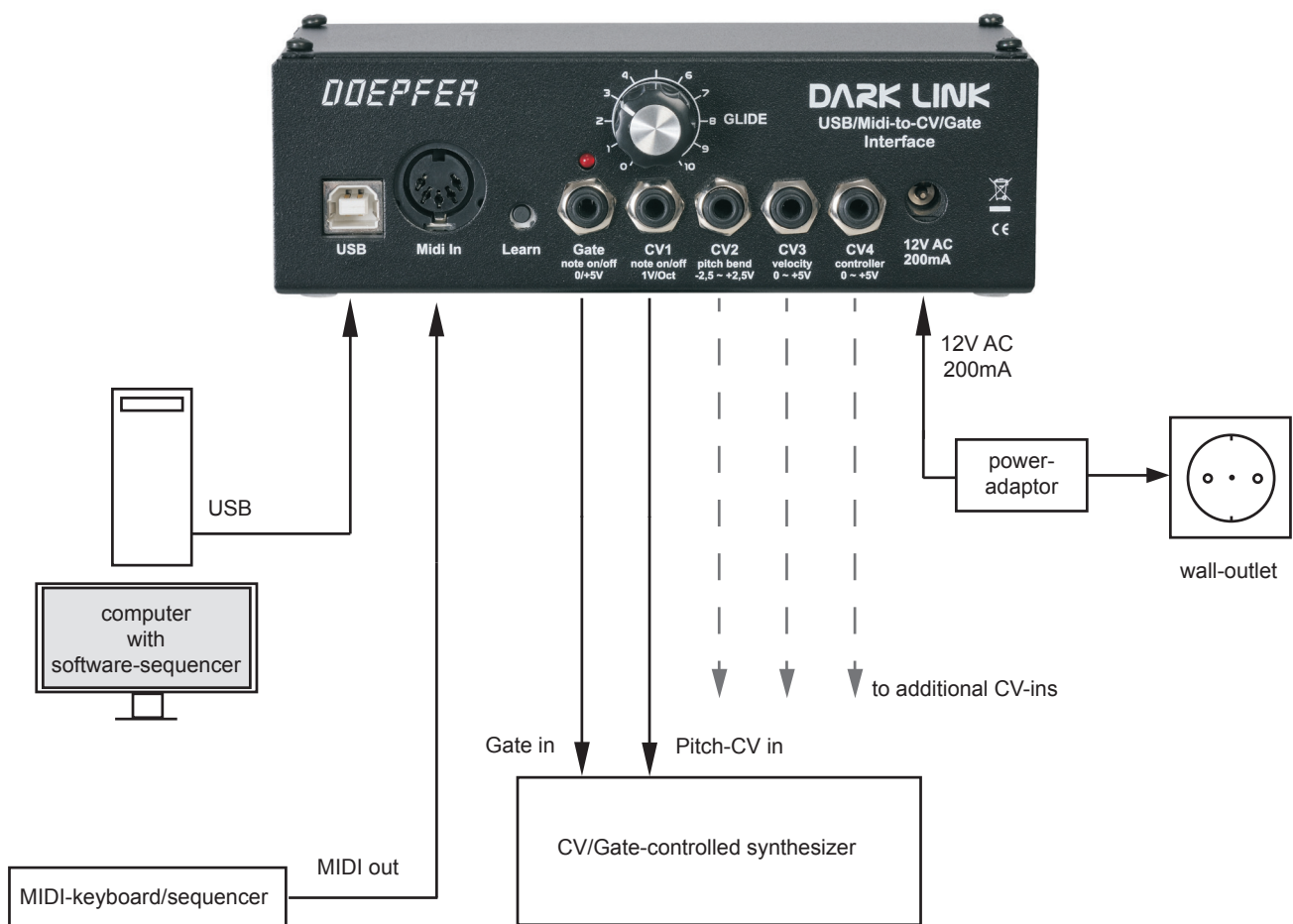

## 2. Overview

Dark Link uses a very simple user-interface. To be exactly, it is not much more than the learn button and one additional knob. The learn-button is used to configurate Dark Link and "tell" it, in which manner it has to transform incoming MIDI data into analogue control voltages and the gate signal.

The GLIDE knob controls the – you guessed it – the glide time of Dark Link's internal glide function.

As a hidden feature, you will also find a simple but useful arpeggiator which is also accessed by the learn button. It's use is pretty simple, even without a display.

Dark Link receives MIDI data via it's USB port **or** the MIDI-IN DIN-socket. Please do **not** use both simultanously.

The five 1/8" mini sockets provide the four controlvoltages and the gate signal, generated by Dark Link.

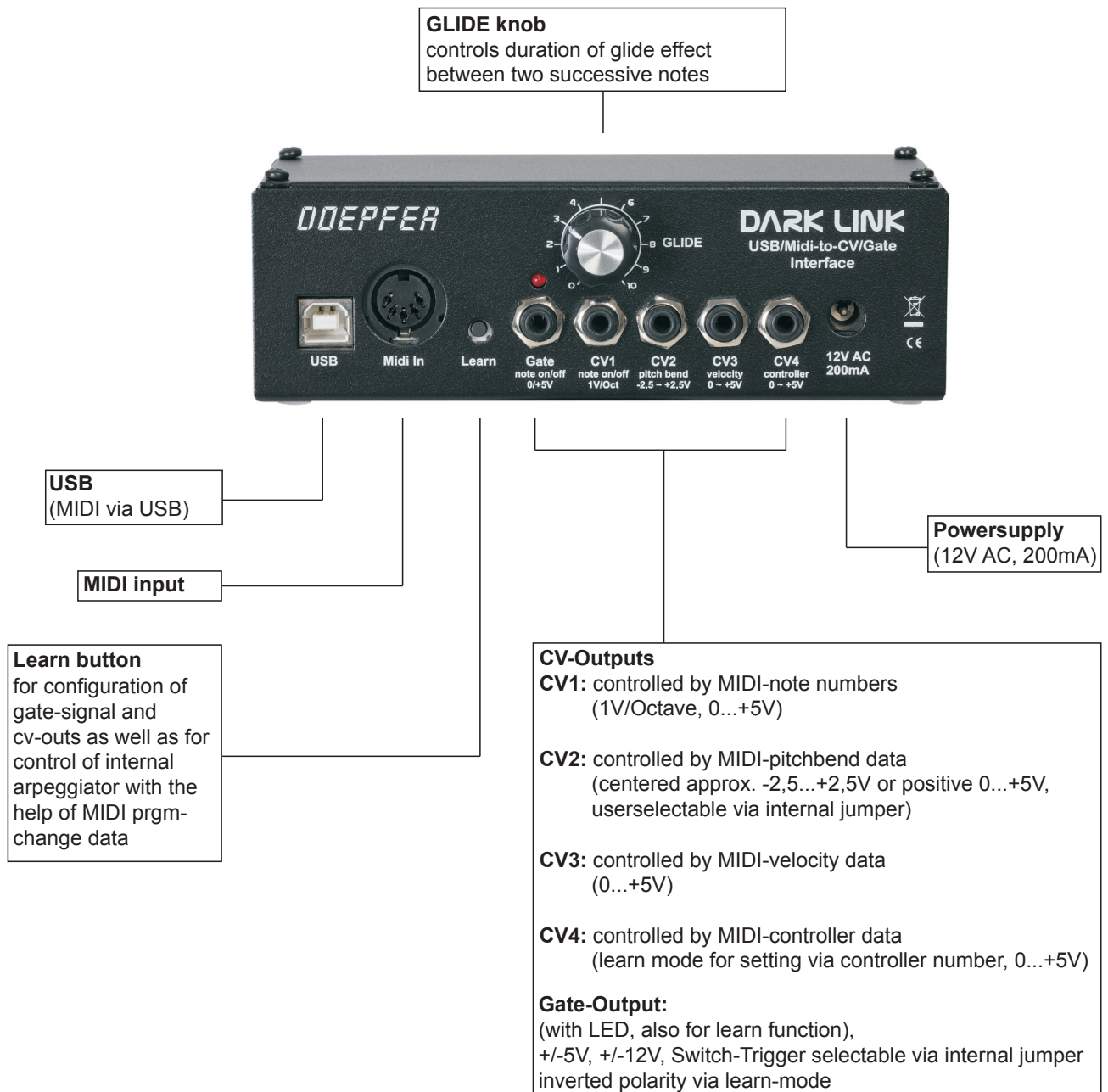



### 3. Functions

In this section, we will explore all of Dark Link's functions in detail. First, we will have another and more closer look at the MIDI/USB hookup. Next to this, we will become familiar with Dark Link's learn mode and the way to configure it's functions easily via MIDI programm change commands.

#### 3.1. MIDI Connection

To connect Dark Link to your MIDI keyboard / controller / computer there are two easy ways to do so:

- MIDI via USB or
- the „traditional“ MIDI-connection via DIN socket.

• *USB*: To hook up Dark Link in your MIDI-setup via USB, simply connect the included USB cable with Dark Link and with an unused USB port on your Mac or Windows PC.

Mac OSX, Windows XP (SP2 or higher), and Windows Vista offer the necessary drivers and Dark Link will be mounted as soon as it has been connected. You will find a new MIDI port in your MIDI application, named „USB audio device“ (Windows XP) or „Dark Link“ (OSX, Windows Vista), and you are ready to go. If this message is missing or an error message is shown, e.g. „USB device not found“, the necessary driver has most likely not been installed or is not working properly on this computer. In this case, Dark Link's USB port unfortunately cannot be used on this specific computer. We apologize for not being able to support this particular problem as there can be various reasons for that misbehavior which are very specific and depend on the individual computer. Of course, you can run Dark Link via the MIDI DIN-connection in such a case without any problems. The same goes for an older system based on Windows or Mac that does not provide you with the necessary drivers.

• *DIN* socket: You may alternatively connect Dark Link via MIDI cable to a MIDI interface, a MIDI keyboard, or a MIDI hardware sequencer. Simply connect the MIDI output of your MIDI device with Dark Link's MIDI port. Please do **not** use USB and DIN connections simultaneously.

#### 3.2. MIDI channel selection (Learn button):

In order to enable Dark Link to receive incoming MIDI messages, the MIDI channel of both the MIDI device and Dark Link have to be identical. This is how you can select Dark Link's MIDI channel:

- Select the desired MIDI channel on your MIDI device / software application. Please refer to their respective user manuals when in doubt.
- Press the „Learn“ button of Dark Link and keep it depressed for at least one second. The LED will start flashing, showing that Dark Link is in „learn mode“. The delay of one second avoids accidental use of the „learn“ mode. The flashing LED always indicates Dark Link's active learn mode. For easy access to the „learn“ button you can use a pen or a plug.
- Press the key on your keyboard with the lowest key that your connected CV/gate synthesizer is supposed to play. This key will set CV1 (pitch CV) to 0 Volt. The available range will cover five octaves above that key. The default setting is MIDI note number 36.
- Now you're done - Dark Links MIDI channel will now correspond to the one of the connected MIDI device. Dark Link will quit learn mode automatically and return to normal running mode. If you enable „learn“ mode accidentally, simply hit the „learn“ button again to quit.

When Dark Link receives a MIDI note, the „learn“ LED will turn off briefly. You may use this as a MIDI-in monitor, without the need to connect a sound system.

### 3.3.2. MIDI to CV/Gate interface

The „USB/MIDI-to-CV/Gate“ interface generates not only a pitch control voltage and a gate signal to trigger the envelope with, it also produces several control voltages derived from incoming MIDI velocity and MIDI controller data. The MIDI-to-CV interface also features a simple but useful arpeggiator and a so-called reference pitch. You have encountered the reference tone before when you selected the MIDI channel - it was the MIDI note that set Dark Link's pitch CV1 to 0 Volts and thus became the lowest key of Dark Link's resp. of the connected CV/gate synthesizer's key range.

All CVs and the gate signal can be tapped from sockets on the front of Dark Link. Use patch cords or adapter cords to connect them with the suitable inputs on your CV/gate controlled synthesizer. In case, your synthesizer is equipped with the suitable inputs, you can control its most important sound parameters dynamically via MIDI velocity and a MIDI controller.



Depending on the incoming MIDI data (note on/off, notenumber, pitch bend, MIDI controller, velocity), the interface will generate:

- The gate signal for the envelope generator: The level of the gate-signal (5V or 12V) as well as switch trigger (needed for some vintage Moog and Korg synthesizers) can be selected via an internal jumper on the board of Dark Link. Default setting is +5V. Please refer to page 15/16. Polarity can be inverted via learn-function. More on this on page 12, note (4).
- CV1: controlled by MIDI note numbers;  
1V/oct scaling  
Range: 0...+5V
- CV2: controlled by MIDI pitch bend data (ranges approx. -2.5V to +2.5V or 0V to +5V, selectable via internal jumper). Default setting is -2,5V to +2,5V. Please refer to page 15/16.
- CV3: controlled by volume or the sum of volume and velocity (selectable via learn mode). Please refer to page 11, note (2).  
Range: 0...+5V.
- CV4: controlled by a freely selectable MIDI controller or the product of controller data and velocity (controller number selectable via learn mode). Please refer to page 11, note (2).  
Range: 0...+5V.

### 3.4. Learn Mode / MIDI Functions

In „learn“ mode you will determine how Dark Link will process incoming MIDI data. In addition to this, you will control the settings of the internal arpeggiator and set the reference tone which will determine the lowest key of Dark Link's resp. your connected CV/gate synthesizer's keyboard range.

You can access each function via MIDI program changes. The table below lists all functions. The notes (1) to (10) explain all functions in detail.

Function	MIDI-Message	Counting 1-128	Counting 0-127	Note	Short Explanation
MIDI-Chan / Ref-Note (CV1=0V)	Note on			(1)	
CV3 Velocity off	Program Change	#1	0	(2)	CV3=Volume
CV3 Velocity on	Program Change	#2	1	(2)	CV3=Volume Velocity
CV4 Velocity off	Program Change	#3	2	(2)	CV4=Ctr.X
CV4 Velocity on	Program Change	#4	3	(2)	CV4=Ctr.X*Velocity
<b>Retrigger</b>					
Off	Program Change	#5	4	(3)	
On	Program Change	#6	5	(3)	
Trigger Polarity Normal	Program Change	#7	6	(4)	
Trigger Polarity Inverted	Program Change	#8	7	(4)	
<b>Key-Assign-Mode</b>					
Highest note	Program Change	#15	14	(6)	
Last note	Program Change	#16	15	(6)	
Reference note	Program Change	#17	16	(6)	
Stack note	Program Change	#18	17	(6)	
Arp. Mode On/Off	Program Change	#19	18	(7)	Arpeggiator
Arp. Mode Hold	Program Change	#20	19	(7)	Arpeggiator
Arp. Mode Overwrite	Program Change	#21	20	(7)	Arpeggiator
<b>Arpeggiator Sync</b>					
Arpeggiator Sync - Intern	Program Change	#22	21	(8)	internal Tempo
Arpeggiator Sync – Extern (Midi Realtime/Clock)	Program Change	#23	22	(9)	external Tempo
<b>Controller für CV4</b>					
	any MIDI- Controller (except Bank-Controller Ctrl#032,			(10)	

Notes:

(1) MIDI channel/reference for CV1=0V

In case of an incoming note event in learn mode, the note number and the channel of the event will be taken as the new reference tone and MIDI channel of Dark Link. The reference key will be the MIDI note number that is assigned to 0V CV1 output. In practice you simply enter the learn mode and press the key on your MIDI keyboard that is supposed to be 0V CV1. MIDI note events below the reference note or higher than 5 octaves above the reference note will be ignored as the CV1 voltage range of Dark Link is 0...+5V. The factory default settings of reference key and MIDI channel are note number 36 (C) and channel 1.

For setting these parameters, MIDI Program Change messages coming from your MIDI device are used. Normally, you will have to press the program change keys on your MIDI keyboard or MIDI synthesizer while in „learn“ mode. Bear in mind that some manufacturers count the MIDI program change numbers from 0 to 127 rather than from 1 to 128 as defined by the MIDI standard. If the lowest program change number you can send with your MIDI device is 0 (zero), you have to subtract 1 from the program change numbers in the table above because in this case the program changes of your device range from 0 to 127 instead of 1 to 128. For some devices (especially software sequencers) the type of program change numbering can be selected. In this case you should use the 1 to 128 range to comply with the numbers in the table above.

The program change messages must be sent on Dark Link's MIDI channel (please refer to section „MIDI channel selection / learn button“ on page 9).

#### (2) Velocity on/off

These program-change messages are used to select whether the note-on velocity affects the control voltages CV3 and / or CV4. If velocity is „off“, only volume (CV3) respectively the unassigned controller (CV4) is used to generate the control voltage. If velocity is „on“, the volume or controller value is multiplied with the note-on velocity, i.e. the CV value changes with every new note event as the velocity of the note event is used to calculate the control voltage together the volume message (CV3) resp. the unassigned controller (CV4).

#### (3) Retrigger on/off

With this parameter you can select whether a new gate/trigger pulse is generated when playing legato (i.e. playing a new key on the keyboard without releasing the key played previously). The factory default setting is „retrigger off“. Additionally, the MIDI controllers legato (controller #68) and sustain (controller #64) affect the gate output in the usual way.

#### (4) Trigger polarity

With this function you may select between not inverted/normal trigger (meaning +5V/+12V when key is pressed and 0V when no key is pressed) and inverted trigger (meaning 0V when key is pressed and +5V/+12V when no key is pressed). If your synthesizer might behave in a reversed way (envelopes are started when key is released instead of being pressed) please simply change the trigger polarity.

***When Dark Link generates a switch trigger (see page 15/16), the polarity also has to be inverted.***

#### (6) CV1 Key Assign Mode (Note Priority)

These program change messages adjust the type of assign modes for CV1.

- If „*highest note*“ is selected, the highest key pressed on the MIDI keyboard is used to calculate CV1 if more than one key is being held.
- In the „*last note mode*“ always the last note played (chronologically) is taken as CV1. „Reference note“ means that only the reference note is accepted. This feature is useful if you want to trigger different devices from the same MIDI channel using two or more Dark Link's. In this case you have to set the reference keys for each Dark Link unit to a different value.

## (7) Arpeggiator

Dark Link features an internal arpeggiator. An arpeggiator splits the notes of a sustained chord into a successive pattern of single notes. In music, splitting chords into a pattern of successive pitches is generally called „arpeggio“. Dark Link’s arpeggiator makes use of the following parameters:

- *Tempo* of the arpeggio can be determined by Dark Link itself or synced to an external MIDI device.
- *Direction* is defined by the order in which the keys have been played on the keyboard.
- *Playback Mode*:
  - *On/off*: Enables the arpeggiator. Set to „on“, a key has to be depressed to become part of the arpeggio. As soon as a key is released, the note will be deleted from the arpeggio pattern. In other words: Only sustained keys will be played back as an arpeggio.
  - *Hold*: In contrast to the „On“ mode, notes will still be played back after the corresponding key has been released. The notes will be deleted from the pattern as soon as they are played a second time. Imagine this function was a „toggle switch“.
  - *Overwrite*: Again, the notes will be played back in the same order in which they have been played on the keyboard. After the sixth note (maximum capacity), the arpeggio will start all over again. This mode will „collect“ played keys, deleting notes selectively is not possible. The entire pattern will be deleted when the arpeggiator is stopped.

## (8) Arpeggiator Sync - internal

Dark Link’s arpeggiator generates its own clock signal. The tempo can be controlled via MIDI modwheel data. Since a modwheel can be found on almost every MIDI keyboard, it is a useful controller to set the tempo of the arpeggiator in realtime (see below).

## (9) Arpeggiator Sync - external (MIDI clock)

The arpeggiator receives tempo data from an external device via the USB/MIDI input. It will process the so-called MIDI realtime events: MIDI Start, Stop, Continue, Clock.

Please note: The arpeggiator will run only if these events are generated and sent by the master MIDI device!

The following realtime parameters can be controlled by several MIDI controller messages (these parameters cannot be saved. After powering down/up Dark Link, they will return to their default settings).

- *Tempo*
  - MIDI controller 1 (Modwheel)
  - Value range: 0 - 127
  - Value 0 = Stop
- *Gate length (note length)*
  - MIDI controller # 0
  - Value range: 0 - 127(Divides the MIDI-clock value or the value of the internal clock. Divider is 1/96.)

- **Octave**

- MIDI controller # 0

- Value range: 0 - 6

(The pattern will be transposed up to 7 octaves, until it starts again with note „one“.)

Since Dark Link's note range covers a maximum of 5 octaves, higher notes will be ignored and produce „pauses“ within the pattern. This effect can be used in a creative way to create musical phrases.

*Example:* With the setting „octave 1“, the played chord A3-C4-F4-G4 will produce exactly the same pattern. Using „octave 2“ instead results in the pattern A3, C4, F4, G4, A4, F5, G5 and so on.

### (10) MIDI controller for CV4

If Dark Link receives a MIDI controller message (except bank controller # 0 and # 32) while in „learn mode“, the controller number of this message will define the controller number for CV4, for instance, the CV4 output of Dark Link will correspond to this controller number from now on. The controller message must be sent on Dark Link's MIDI channel (see section „MIDI channel / Learn mode“ on page 17). Controller # 0 and # 32 (Bank Change) will be ignored and cannot be „learned“.

Whenever Dark Link receives one of the MIDI messages listed in the table above, the parameter in question will be changed and Dark Link will return to normal play mode, i.e. the LED will stop flashing. Make sure that no accidental MIDI messages appear while in learn mode (e.g. from a sequencer) as you alter the settings of Dark Link by such MIDI messages. All parameter changes made while in learn mode are stored in Dark Link's non-volatile parameter memory. When Dark Link is turned on next time, the parameter settings will be loaded from this memory.

## 3.5. The GLIDE control



A popular effect – or rather playing technique – is letting one note's pitch slide gradually to the pitch of the note played next. You get this effect (on a suitably equipped synthesizer) when hitting a new key before releasing the preceding one (i. e. legato playing). This function is also part of Dark Link. Synthesizers that do not feature this function can now easily be tricked into doing it without any further modifications necessary. Cool stuff, eh? Unfortunately, some vintage synthesizers lose their built-in glide function when controlled by external CV/gate signals (e.g. Moog Prodigy). These

instruments will also benefit from Dark Link's glide function.

Dark Link's GLIDE knob sets the time that it takes a note to slide up or down to the pitch of the note played subsequently. Simply turn the knob to the desired value to enable Dark Link's glide function. The glide function affects CV1.

## 3.6. Resetting Dark Link

In order to return to the factory settings of all parameters, you have to reset the device. This might be useful if, for instance, you do not remember the last parameter settings (e.g. MIDI channel, reference note, controller # for CV4, key assign mode) or if they are out of alignment. If your Dark Link seems to behave in strange ways and you do not know how to solve the problem, resetting the device may help as the values of all parameters will be restored after the reset.

To reset the device, depress and hold the learn button while the power supply is plugged in. The LED will light up and you have to keep the button depressed for a few seconds until the LED starts flashing. Pressing the button again gets you back into normal operation mode and the LED will turn on.

After resetting, Dark Link's parameters are set to the following default values:

- MIDI channel 1
- Reference note 36 (i.e. the lowest „C“ on a standard 5-octave keyboard)
- Retrigger: on
- CV3: volume (controller #7)
- CV4: modulation (controller #1)
- Key assign mode: highest note
- Internal Arp-Tempo: approx. 120 BPM
- Gate length: 6
- Octave: 1
- Arpeggiator Sync: internal

These values are identical with the factory default settings.

### 3.7. Firmware Update

Dark Link's firmware can easily be updated via USB. In case a new firmware version is available, you can download it from our website ([www.doepfer.de](http://www.doepfer.de)). A detailed description of the update process can be found in the additional technical description of Dark Link. You can download this documentation here:

[www.doepfer.de](http://www.doepfer.de) -> Products -> Dark Link -> Additional technical documentation

### 3.8 Changing gate signal and CV2 range by setting internal jumpers (ser-no. 112700 and higher)

- Dark Link can generate **gate signals** of 5V or 12V as well as switch triggers. You can select the desired trigger signal by simply setting the internal jumper **JP1** on Dark Links circuitboard.
- The MIDI pitchbend related control voltage **CV2** can have two different ranges: -2,5V to +2,5V or 0V to +5V. Please select the desired voltage range by setting the internal jumpers **JP2A / JP2B** on Dark Links circuitboard.

How to set the jumpers JP1 and JP2A / JP2B:

- Pull off Dark Links power plug and open the box carefully with a fitting scwdriver.
- Localise jumper JP1 and jumpers JP2A / JP2B on the circuitboard (see page 16).
- Set the jumper into the desired position. Avoid touching other parts and soldering side of the circuitboard.
- Close the box again.

JP1 position for 5 Volts gate signal (middle and rightmost contacts – default setting)

JP2 position for CV2 range -2,5V to +2,5V (set to JP2A – default setting)

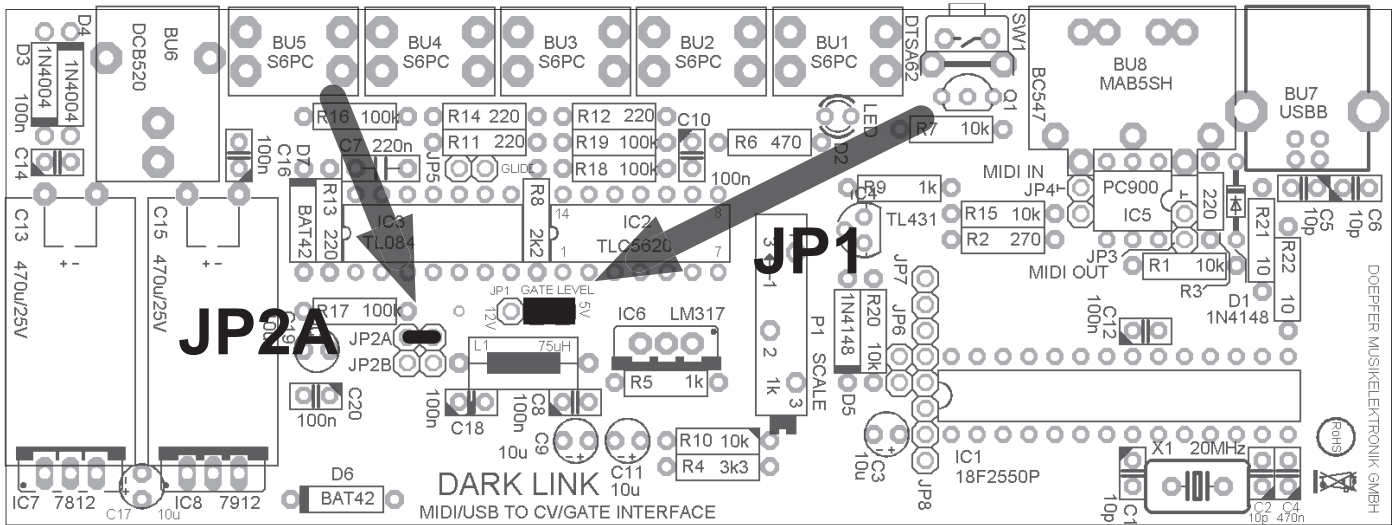

JP1 position for 12 Volts trigger (middle and leftmost contacts)

JP2 position for CV2 range 0V to +5V (set to JP2B)

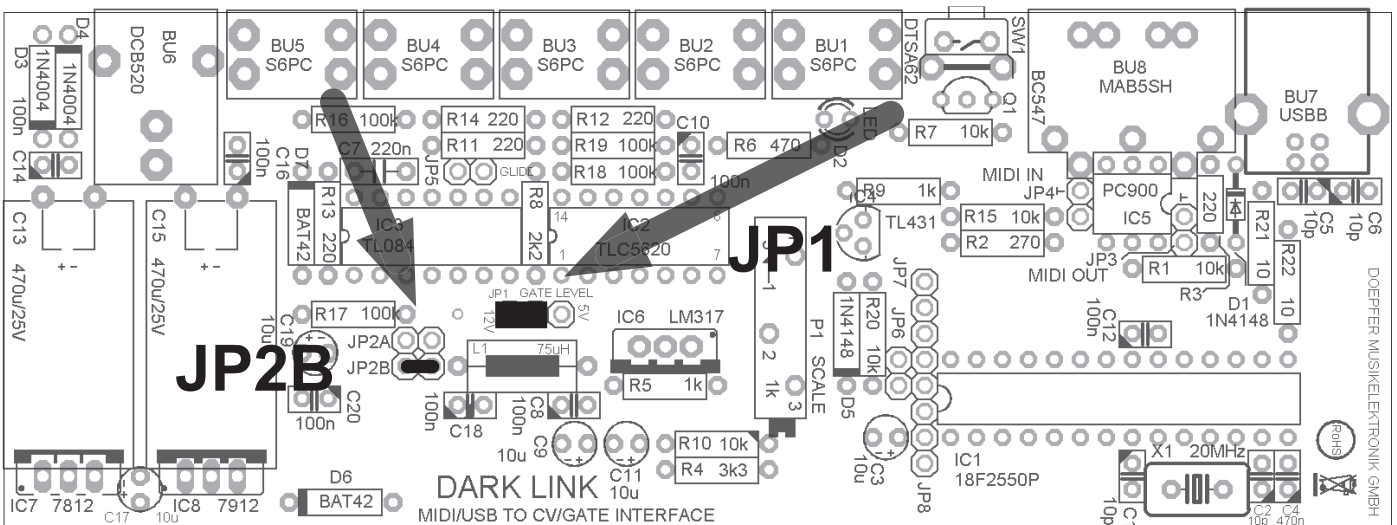

To generate a switch trigger, the jumper (JP1) has to be taken off.

**Please note that it is necessary to invert the trigger polarity when generating a switch trigger. Please refer to page 12, note (4).**



## 4. Nuts and bolts of MIDI to CV/Gate conversion

As you may certainly know, synthesizers from the early days of electronic music (1970s and early 1980s) used so-called „analog“ sound generators. Oscillators, filters, and amplifiers generated and processed sound while parameters as pitch, timbre, and volume were controlled by analog voltages. The voltage that controls pitch is usually generated by the instrument's keyboard: The further up the keyboard, the higher the control-voltage and thus the higher the pitch of the note generated by the oscillator. Easy as that.

The loudness contour of an analog synthesizer is generated by an envelope generator. This requires a certain signal to get it started, the "gate" or "trigger" which is also generated by the keyboard. To make a long story short: To make an analog synthesizer produce a sound (in the most simple case), a control voltage to determine pitch, and a gate signal to fire off some tone, are required.

When MIDI came up, the technology to control a synthesizer with changed completely. MIDI transmits pitch, loudness, note-on, and note-off information as digital data (plus some additional stuff as well).

To connect both worlds – i. e. the integration of a classic analog synthesizer into a contemporary MIDI-based setup – we need a converter that translates digital data into analog voltages. This is exactly what Dark Link does.

In those days of yore (see above), not all specifications were subject to technical standards. Some manufacturers opted for their own designs. Due to these idiosyncracies, some of the most sought-after vintage synthesizers have different specifications in terms of controlling pitch and firing off envelope generators. You ought to keep this in mind when using them in connection with a MIDI to CV/Gate interface.

### Voltage control of pitch / scaling

With most analog synthesizers, increasing the voltage controlling pitch by one volt means increasing pitch by one octave. This so-called volt/octave scaling has since become a common standard and is still valid for contemporary analog synthesizers. Doepfer's A-100 modular system and the Doepfer compact synthesizer Dark Energy also use this standard. That is why Dark Link makes use of it as well. Alas, a handful of vintage synthesizers (e.g. Korg MS-models and Yamaha CS-models) make use of different types of scaling, thus cannot be played tonally in combination with Dark Link.

On most analog synthesizers the input socket for controlling pitch externally is labeled "KBD in", "VCO CV in", „KEY Volt in", "Oscillator CV in" or something along these lines. Plug Dark Link's CV1 into this input.

### Gate

There are also different ways of getting the envelope generators of some synthesizers going. The most commonly used standard is a positive gate signal, i. e. a positive voltage when a key is held down and zero volts when no key is depressed. Nearly all manufacturers of now classic synthesizers made use of that system, e.g. Roland, ARP, Oberheim, Sequential, you name it. If your synthesizer is one of the rare breed that works in a reversed way (a positive voltage when no key is pressed and zero volts when a key is depressed), Dark Link can be set up to match this as well (see page 12, note (4)). If that is no good news, we honestly do not know what is.

There is also no common standard concerning the level of the gate signals on vintage synths. Some manufacturers used voltages around 5 V, others 10-12V. Again – Dark Link is prepared: Simply set an internal jumper to adapt the gate-voltage setting to your needs. Please refer to page 15/16 of this manual.

Some vintage Moog synthesizers (e.g. the Mini Moog or the Prodigy) require a so-called "switch trigger" or "s-trigger". Setting the internal jumper on Dark Link's board will enable it to generate a switch trigger as well. Please bear in mind that you reverse trigger polarity by using switch trigger. If your synthesizer behaves strange (in an undesired way, mind you) like envelopes being triggered when a key is released rather than being pressed, please simply change the trigger polarity of Dark Link.

With most analog synthesizers, the input socket for an external gate signal is labeled "GATE in", "TRIG in", "S-TRIG in", "KBD in" or something like that. Connect it to Dark Link's CV1 output.

### **Additional Control Voltages**

Dark Link can generate three additional control voltages that can be very handy when it comes to addressing further parameters of your analog synthesizer.

CV2 is derived from the pitch bend information of the MIDI-keyboard connected. If your synthesizer sports an additional input for pitch control, use this in connection with CV2. In order to use CV2 as flexible as possible, its range can be selected between -2,5V to +2,5V or 0V to +5V by setting an internal jumper. Please refer to page 15/16.

CV3 is derived from the velocity information of the MIDI-keyboard connected. Patch CV3 into the filter and/or amplifier control-voltage inputs of your synthesizer. This gives dynamic control of timbre and/or volume – just like on a modern synth.

With most analog synthesizers, the input sockets for external filter and volume modulation are labeled "VCF in", "VCF fcm", "Filter-CV" or, respectively, "VCA", "Volume", "Loudness" or something like this. Connect these to Dark Link's CV3 output.

CV4 is derived from a user-selectable MIDI controller, generated by the MIDI-keyboard connected. The most commonly used MIDI controller would be #1 which is the mod wheel. Depending on the interfacing options of your synthesizer, you can use this control voltage in various ways.

In case your analog synthesizer is not equipped with standard mini jacks (1/8"), please use matching adaptor cables.

## 5. Addendum

### Service and terms of warranty.

Concerning service and warranty conditions, please refer to our terms of business.  
You will find our terms of business at:

[www.doepfer.de](http://www.doepfer.de)

Doepfer Musikelektronik GmbH  
Geigerstr. 13  
D-82166 Gräfelfing / Deutschland

---

#### EG Conformity

Für das als Doepfer Musikelektronik GmbH „Dark Link“ bezeichnete Produkt wird hiermit bestätigt, dass es den Schutzanforderungen entspricht, die in der Richtlinie 89/336/FWG des Rates zur Angleichung der Rechtsvorschriften der Mitgliedsstaaten über die elektromagnetische Verträglichkeit festgelegt sind. Es entspricht außerdem den Vorschriften des Gesetzes über die elektromagnetische Verträglichkeit von Geräten (EMVG) vom 30. 08. 1995. Zur Beurteilung des Produkts wurden folgende harmonisierende Normen herangezogen:

EM 50 082-1: 1992, EN 50 081-1 : 1992, EN60065 : 1995

Please refer to our website „terms of business“.

#### Disposal

This device complies to the EU guidelines and is manufactured RoHS conform without the use of lead, mercury, cadmium and chrome. Still, this device is special waste and disposal in household waste is not permitted.

For disposal, please contact your dealer or :

Doepfer Musikelektronik GmbH, Geigerstr. 13, D-82166 Gräfelfing / Deutschland

---

#### IMPRINT

Owners Manual by Matthias Fuchs / VISOPHON, Berlin, Germany

English version tweaked and adjusted by Stephen Parsick / doombient music, Bielefeld, Germany

Copying, distribution or any commercial use in any way is prohibited and needs the written permission by the manufacturer.

Specifications subject to change without notice.

Although the content of this owners manual has been thoroughly checked for errors, Doepfer Musikelektronik GmbH cannot guarantee that it is error-free throughout. Doepfer Musikelektronik GmbH cannot be held liable for any misleading or incorrect information within this guide.

# DOEPFER

Doepfer Musikelektronik GmbH  
Geigerstr. 13  
D-82166 Gräfelfing / Deutschland

[www.doepfer.de](http://www.doepfer.de)

# **DARK LINK**

*DOEPFER MUSIK ELEKTRONIK GMBH*